

Structure of DNA Metal Complexes in Solution Studied by Linear and Circular Dichroism. $[\text{Pt}(\text{II})(\text{ethylenediamine})(2,2'\text{-dipyridine})]^{2+}$ Binds Strongly to DNA by Intercalation. $[\text{Cu}(\text{II})(2,2'\text{-dipyridine})_2]^{2+}$ is not Intercalated

BENGT NORDÉN

Inorganic Chemistry 1, University of Lund, Chemical Center, P.O. Box 740, S-220 07 Lund, Sweden

Received March 1, 1978

We have studied the interaction between B-form DNA in dilute aqueous solution and $[\text{Pt}(\text{ethylenediamine})(2,2'\text{-dipyridine})]^{2+}$ (I) and $[\text{Cu}(2,2'\text{-dipyridine})_x]^{2+}$, $x = 1$ (II) and 2 (III), by means of linear dichroism (LD) and circular dichroism (CD). LD and two-phase partition equilibrium analysis reveal a strong DNA complex with I (0.005 M NaCl: $K = 2 \times 10^6 \text{ M}^{-1}$, $n = 0.17$ ligands per nucleotide residue; 0.1 M NaCl: $K = 10^5 \text{ M}^{-1}$, $n = 0.08$). No spectroscopic evidence was obtained for any complex with II. A fairly strong complex is formed with III (0.005 M NaCl: $K = 10^5 \text{ M}^{-1}$, $n = 0.2$; 0.1 M NaCl: $K = 10^5 \text{ M}^{-1}$, $n = 0.05$).

Conclusive structural evidence is provided by the specific linear and circular dichroisms of these complexes. $[\text{Pt}(\text{en})(\text{dipy})]^{2+}$ is oriented with its plane parallel to the planes of the DNA bases. Together with the stability data this strongly indicates a binding according to the intercalation model of Lerman. The non-planar $[\text{Cu}(\text{dipy})_2]^{2+}$ behaves quite differently with an average of 40° between the Cu dipy planes and the base planes. This complex is not intercalated but is most probably bound in the large groove by a Cu-base nitrogen coordination.

Introduction

Since the observations by Rosenberg and coworkers on the cytotoxicity [1] and anticancer activity [2, 3] of platinum(II) compounds the interaction of platinum with DNA has drawn considerable attention (see e.g. review by Williams [4]). With the advent of bioinorganic chemistry there has also followed a general interest in the interaction of metal ions with polynucleotides and related natural multisite ligands (see e.g. Eichhorn [5, 6] and others [7, 8]). However, although there have been many studies of the interactions of metals with polynucleotides, the amount of concrete knowledge available in terms of structure, location of sites, stability, base specificity, and so on, is still surprisingly modest. The more comprehensive solution studies have been restricted to metal complexation with nucleic acid components and can thus

be expected (for steric and other reasons) to have fairly little in common with the corresponding polynucleotide complexes. The same simplifications are often found in crystallographic works dealing with "nucleic acids".

On the other hand, with real polynucleotides the information yield is more limited as may be illustrated by the results of a recent X-ray diffraction study on DNA fibers containing 2-hydroxyethanethiolato(2,2', 2''-terpyridine)platinum(II) which strongly indicated that the platinum atoms are regularly distributed at 10.2 Å intervals [9]. Nuclear magnetic resonance spectroscopy is potentially one of the most valuable techniques for obtaining specific information about interactions in solution, but again, for various reasons (requirement for large concentrations, alternative interpretation possibilities, etc.) [7] the conclusiveness is severely reduced. Electron paramagnetic resonance seems to provide a useful way to monitor certain free metal ions (e.g. Mn^{2+}) [10]. Optical spectral techniques most notably UV absorption, optical rotary dispersion (ORD) and circular dichroism (CD) have been applied extensively in studies of metal ion interactions with polynucleotides. The sensitivity of these methods is quite sufficient but the results are usually difficult to interpret: a recent report that binding of Pd(II) to DNA brings about considerable "conformational changes" is an example of a typical conclusion in circular dichroism investigations [11].

We recently showed [12] that linear dichroism due to the association of a coloured metal complex to flow-oriented DNA can provide a basis for a routine analysis with excellent structural information potential. Flow dichroism had previously been used only sporadically, mainly in conformation studies on biopolymers [13–16]. The combination of a scanning linear dichroism spectrometer [17–19] with a suitable flow cell makes it possible to study dilute solutions, rapidly, and with a high accuracy of measurement [20]. A few reports on dichroism spectra of polynucleotides and polypeptides with amino-acridines or similar dyes as ligands have been published, but the lack of working orientation models seems to have

precluded more conclusive interpretation [13, 20–24]. The main obstacle is the fact that the orientation distribution must consider not only rotational motion but also a conformational distribution due to the flexibility. We have recently pointed out [13, 20–24] that this can be circumvented since the dichroism (integrated over the distributions) factorises into an orientation factor, which can be determined empirically, and an “optical factor” which characterises the local structure. We have further shown [12, 20] that linear dichroism can be used as a conclusive test of binding: if a chromophoric ligand is subjected to binding forces from an oriented macromolecule its own orientational distribution will be more or less perturbed so that it will deviate from the random distribution and a linear dichroism signal in the ligand absorption results. *Vice versa*, all experience indicates that absence of LD is a reliable criterion of the absence of (stronger) binding (*cf.* ref. 27). For instance of a variety of anions studied in this way, none has been found to give interaction LD with DNA.

In the present study two metal complexes with DNA are reported which can be characterised by means of their specific linear dichroisms and these results can be interpreted in structural terms. This seems to be one of the first dichroism studies of biopolymer–metal complexes (in a qualitative study we have recently demonstrated an interaction between some inert* metal complexes and DNA [12]).

Experimental

Linear dichroism, $LD = A_z - A_x$, was measured on the sample solution in the circular space between an outer (static) and an inner (rotating) quartz cylinder according to the geometry in Fig. 1. Total optical path-length: 2×0.050 cm. A rotation speed of the angular velocity ω corresponds to a practically constant (over the annular gap) gradient $G \approx \omega R/s$. No indication of any Taylor instability was observed. A JASCO J-40 circular dichroism spectrometer complemented with a quarter-wave prism (“Oxley prism”) was used according to previous methods [17–19]. The arrangement is equivalent to that obtained by using an elasto-optic modulator and a phase-detection tuned for LD [29]. The calibration was made with the aid of a tilted quartz plate [18, 19]. Circular

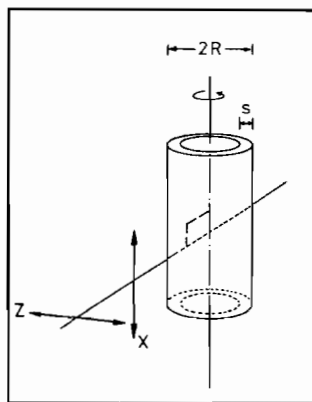

Fig. 1. Geometry of measuring arrangement with the rotation cell ($2R = 3.00$ cm, $s = 0.050$ cm).

dichroism (CD) was measured on a JASCO J-41 “spectropolarimeter” and absorption on a Cary 118-C spectrophotometer.

Defining the site concept so that each site S_i has its specific linear dichroism, $\Delta\epsilon_i$ ($M^{-1} \text{ cm}^{-1}$) the linear dichroism observed at a given wavelength, λ will be:

$$LD(\lambda)/d = \sum_i \Delta\epsilon_i(\lambda)[S_i L] + Q(\lambda) \quad (1)$$

where d is the path-length, L the ligand and Q the intrinsic dichroism of the macromolecule. A great advantage is that a wavelength where $Q=0$ and $\Delta\epsilon \neq 0$ can usually be found. The ligand number

$$\bar{n}_i = [S_i L]/C_{S_i}$$

(where C_S is the total site concentration) is approximately $\bar{n} \equiv LD/\Delta\epsilon C_S \approx LD/LD_{\max}$ in the case $Q=0$ and we have a single site with a large stability constant:

$$K_1 = [S_1 L]/[S_1][L] \quad (2)$$

Introducing the ligand site density $n_1 = C_S/C_N$, where C_N is the total nucleotide concentration, the equilibrium analysis is conveniently carried out by means of a plot of $(1 - \bar{n})^{-1}$ versus C_L/\bar{n} :

$$(1 - \bar{n})^{-1} = K_1 C_L/\bar{n} - K_1 n_1 C_N \quad (3)$$

yielding K_1 as the slope and n_1 from the intercept on the abscissa. The addition of ligand causes a certain dilution which is corrected for in LD and in C_L . The dilution effect in C_N causes an upwards tendency in $(1 - \bar{n})^{-1}$ at high C_L/\bar{n} which can be iteratively adjusted for in the last term of equation 3. When the stability has been determined, $\Delta\epsilon$ can be calculated. When $Q=0$ and there is only one complex one may instead form the ratio:

$$\frac{\Delta\epsilon(S_1 L)}{\epsilon_r(S_1 L)} = \frac{LD}{A_r - \epsilon_r[L]d} \quad (4)$$

*Note that while numerous metal complexes, *e.g.* the “anti-cancer” *cis*-[Pt(NH₃)₂Cl₂], are said to form “complexes” with nucleic acid, few are really associated in unsubstituted form. An example of an unchanged (substitution inert) metal complex that forms a complex with DNA is [Pt(2,2',2''-terpyridine)(SCH₂CH₂OH)]⁺, recently reported by Jenette, Lippard and co-workers [28].

where ϵ_r and A_r are the absorption coefficient and the absorbance of the random solution.

The ratio $\Delta\epsilon/\epsilon$ can be used as an index of the structure of the complex in that it reflects the average orientation of the absorbing transition dipole of the ligand with respect to the orientation axis of the macromolecule. In the classical study of Wada on flow dichroism [13], the angle θ between the transition moment and the long-axis of a rigid prolate spheroid is given by the formula $\Delta\epsilon/\epsilon = F \cdot \frac{3}{2} (3\cos^2\theta - 1)$ where F is the orientation factor for the long-axis. As pointed out elsewhere the dichroism factorises so that even for the case of non-rigid biopolymers like DNA, we obtain an equation of the form [25, 26]:

$$\frac{\Delta\epsilon}{\epsilon} = S \frac{3}{2} (3\cos^2\theta - 1), 0 \leq \theta \leq 90^\circ \quad (5)$$

The order parameter S then however refers not to the orientation of the macromolecule as a whole but to the orientation direction of a small stiff segment: in DNA the direction is the normal to the base plane. If all segments can be considered equivalent $\cos^2\theta = \cos^2\theta = 0$ for the $\pi \rightarrow \pi^*$ transitions in the DNA bases. This enables S to be determined from LD/A at 257 nm. This empirical determination of the order parameter may seem trivial but is in fact a great improvement over previous estimates based on theoretical models. Correspondingly, if all ligands are equivalently oriented with respect to the bases we get the orientation angle θ of the ligand transition with respect to the base normals. Since $\Delta\epsilon/\epsilon$ only provides a measure of the average $\cos^2\theta$, conclusions about the distribution (in time and/or between the sites) can only be made when $\cos^2\theta$ approaches 1 or 0.

The spectra are mostly reproduced as they were recorded: A in absorbance units, CD and LD in ellipticity units (degrees). LD is obtained in absorbance units by division by 33.0.

Calf-thymus DNA (Sigma, type I) was used in an ionic medium of NaCl. Experiments with the Cu complex in a 0.005 M NaAc/HAc buffer at pH = 5.0 indicated that the metal did not cause any undesirable pH effect.

[Pt(ethylenediamine)(2,2'-dipyridine)](NO₃)₂ was synthesised according to Morgan and Burstall [30]. IR and PMR spectra were consistent with this composition of the complex ion.

[Cu(2,2'-dipyridine)₂](ClO₄)₂ was a gift from Dr. Åke Davidsson. The absorption of a 1.00×10^{-3} M solution agreed within 5% with that of a 1.00×10^{-3} M CuSO₄, 2.00×10^{-3} M dipyridine solution. Stabilities of [Cu(dipy)_x]²⁺: logK₁ = 8.1, logK₂ = 5.5, logK₃ = 3.4 in 0.1 M KCl [31].

The two-phase partition method was developed by Prof. P.-Å. Albertsson [32]. It employs 4% aqueous dextran and 5% aqueous polyethyleneglycol. This gives two phases (bottom and top, respectively) of

approximately equal volumes (denoted V_B and V_T). In 0.005–0.1 M NaCl media DNA is exclusively in the dextran phase. The free ligand concentration in the top phase, [L]_T, was analysed spectrophotometrically and via the partition coefficient, K_P = [L]_T/[L]_B (K_P was 1.1 for the Pt complex, 1.2 for the Cu complex) the free ligand concentration in the bottom phase, [L]_B was obtained. The total ligand concentration in the bottom phase was obtained as

$$C_{L,B} = (m - V_T[L]_T)/V_B \quad (6)$$

where m is the added amount of ligand (mol) in the sample. The result was displayed as a plot of $(C_{L,B} - [L]_B)/[L]_B$ versus $(C_{L,B} - [L]_B)$ which according to the equation (one complex only):

$$(C_L - [L])/[L] = n_1 K_1 C_N - (C_L - [L])K_1 \quad (7)$$

yields K₁ from the slope and n₁ from the intercept.

Results

Optical Properties of DNA-L Mixtures

When [Pt(en)(dipy)]²⁺ is added to an aqueous DNA solution only modest changes occur in the UV absorption spectrum (Fig. 2). In the linear dichroism, however, as is seen in Fig. 2 the presence of a complex between the "ligand" [Pt(en)(dipy)]²⁺ and DNA is unequivocally demonstrated by the appearance of LD at the absorption of the ligand. The LD spectrum has a strong negative peak at 323 nm and another (negative) component at 313 nm. The LD bands can be identified with the transitions occurring at 317 and 305 nm respectively in the free ligand absorption spectrum. They have been found to be polarised in the plane of the metal complex by using an oriented matrix technique [33, 34]. The shifts between the maxima in LD and A are significant for the complex and are not due to that LD only reflects the (shifted) absorption of bound ligands while A also includes the (unshifted) absorption of free ligands. The unpolarised absorption is thus practically unshifted while in the copper complex a red-shift of about 2 nm is observed (*vide infra*). The complex formation is also accompanied by the appearance of a negative CD band at the ligand absorption (Fig. 2).

A wide region with positive LD between 350–400 nm corresponds to a weak absorption developed in the complex. A careful study of the LD as a function of the solid angle of observation showed that contributions from polarised scattering were negligible. The observed intensity is thus due to the "true" absorption. Comparison of A, LD and CD (represented in Fig. 2 with their respective noise levels) demonstrates a clear advantage of LD as an indicator of the complex with DNA. (This is further illustrated by the LD spectrum in Fig. 4 below, at higher S and higher C_N). Figure 3 shows how LD becomes saturated

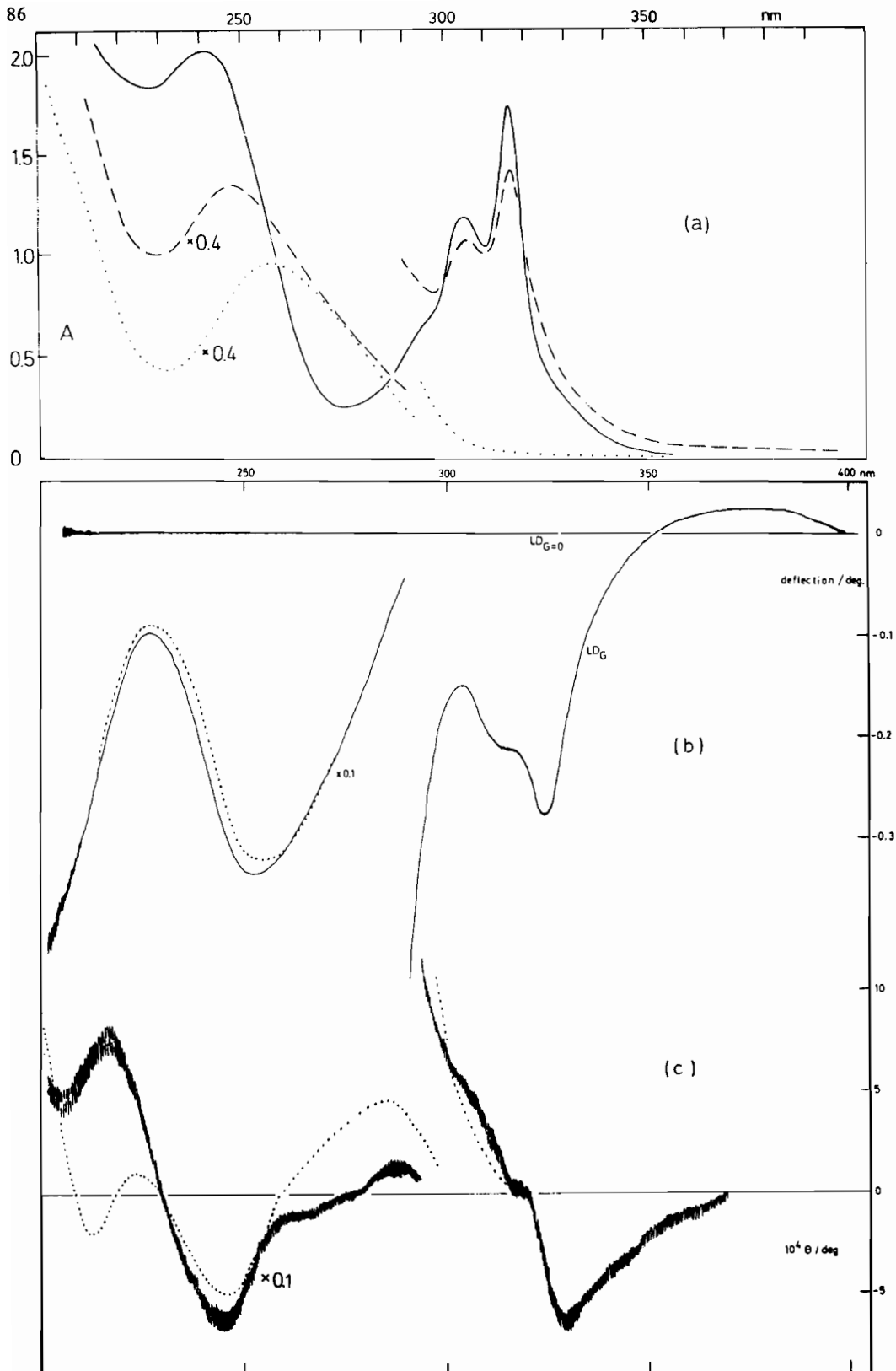

Fig. 2. Absorbance, A (a , 1 cm path-length, absorbance units), linear dichroism, LD (b , 0.1 cm path-length, instrument deflection in ellipticity units at the gradient $G = 2000 \text{ s}^{-1}$) and circular dichroism, CD (c , 1 cm path-length, ellipticity units) of $[\text{Pt}(\text{en})(\text{dipy})]^{2+}$ ($C_L = 9.9 \times 10^{-5} \text{ M}$) + DNA ($C_N = 33.6 \times 10^{-5} \text{ M}$) (solid lines in CD and LD , broken in A) and of pure DNA ($C_N = 37 \times 10^{-5} \text{ M}$, ...) and of pure ligand ($C_L = 9.9 \times 10^{-5} \text{ M}$, — in A) Typical noise levels (time constant 1 s) are shown in two of the LD and CD spectra.

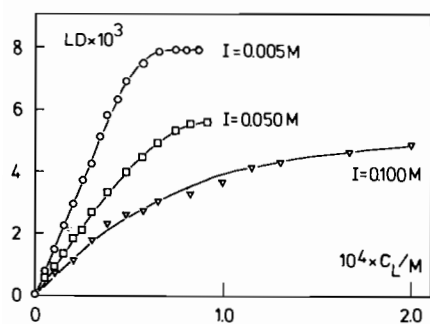

Fig. 3. LD signal (323 nm, $G = 2000 \text{ s}^{-1}$) due to $[\text{Pt}(\text{en})(\text{dipy})]^{2+}$ bound to DNA ($C_N = 39.4 \times 10^{-5} \text{ M}$) as a function of the ligand concentration (C_L) at some different ionic strengths.

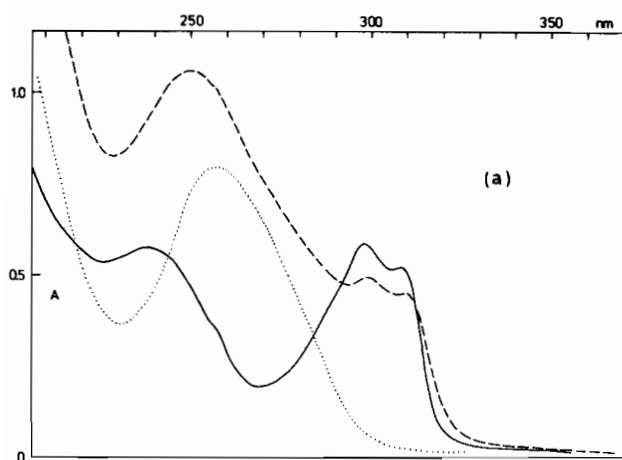

Fig. 4. Absorbance (a) and linear dichroism (b) of a solution $[\text{Cu}(\text{dipy})_2]^{2+}$ + DNA ($C_L = 2.0 \times 10^{-4} \text{ M}$, $C_N = 11.8 \times 10^{-4} \text{ M}$) and of pure DNA ($C_N = 11.8 \times 10^{-4} \text{ M}$) and pure ligand ($C_L = 2.0 \times 10^{-4} \text{ M}$). Curve notations, pathlengths etc. as in Fig. 1. The very high measuring precision in LD is demonstrated by a facsimile of spectra recorded at $G = 0$ and 2650 s^{-1} , sensitivity $10^{-2} \text{ deg cm}^{-1}$ and $10^{-1} \text{ deg cm}^{-1}$, time constant 0.25 s. c. Circular dichroism of DNA ($C_N = 3.3 \times 10^{-4}$, ...) and of $[\text{Cu}(\text{dipy})_2]^{2+}$ + DNA ($C_N = 3.0 \times 10^{-4}$, $C_L = 1.07 \times 10^{-4}$, —) and of bipyridyl + DNA ($C_N = 3 \times 10^{-4} \text{ M}$, $C_L = 0.82 \times 10^{-4} \text{ M}$, - - -).

when all sites are occupied. This point is as expected particularly marked with a low ionic strength.

When $[\text{Cu}(\text{dipy})_2]^{2+}$ is added to an aqueous DNA solution the formation of a complex is similarly revealed through the appearance of LD, as well as by CD, in the ligand absorption bands (Fig. 4). The specific LD is weaker than for Pt but still obviously measurable with high accuracy. The LD spectrum is characterised by a double-humped positive peak at 303–313 nm and a negative weak band at 324 nm. The CD spectrum exhibits a positive peak at 316 nm (with a shoulder at 305 nm). As was mentioned a small shift occurs in the ligand absorption. Optical characteristics are summarised in Tables I–II.

Stability and Structural Data

In Fig. 3 the curve at lowest ionic strength exhibits the saturation which is a prerequisite for the approximation $\bar{n} \approx \text{LD}/\text{LD}_{\text{max}}$. It is seen from Fig. 5a that

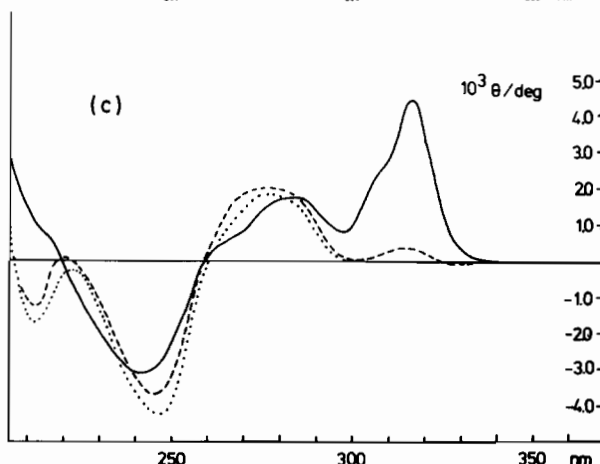
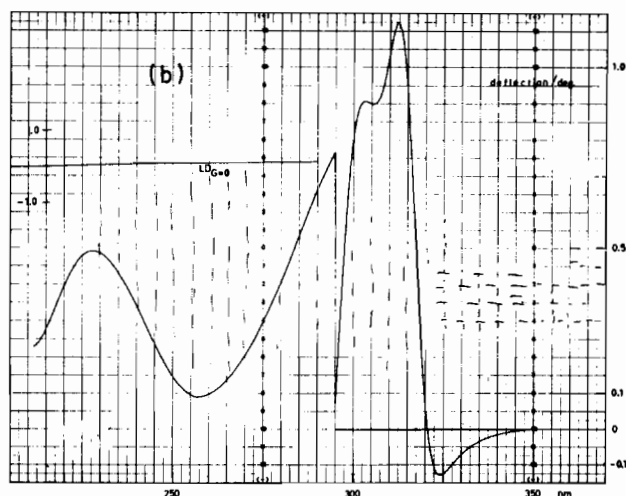

plots of $(1 - \bar{n})$ versus C_L/\bar{n} at two different C_N give straight lines (corresponding to $K_1/10^6 \text{ M}^{-1} = 2.0 \pm 0.5$ and 1.2 ± 0.5 and $n_1 = 0.15 \pm 0.05$ and 0.12 ± 0.05). This procedure is less certain at higher ionic strengths, where the saturation is more asymptotic, however the values obtained are quite reasonable in view of the probably predominant electrostatic free energy contributions in these DNA complexes. These results are essentially confirmed by the free ligand measurements (*vide infra*).

Correspondingly, for $[\text{Cu}(\text{dipy})_2]^{2+}$ the LD versus C_L dependency is consistent with a complex with $K_1/10^6 \text{ M}^{-1} = 0.5 \pm 0.2$ and $n_1 = 0.20 \pm 0.03$ (Fig. 5b). As will be shown in the discussion, the DNA complex with $[\text{Cu}(\text{dipy})_x]^{2+}$ strongly predominates over that with $x = 1$.

Table I summarises the results of the equilibrium analyses, including those from the partition experiments (*cf.* Fig. 9 below), together with the observed

TABLE I. Linear Dichroism and Stability Data for the DNA Complexes.

Ligand	Medium: NaCl, I/M	Linear dichroism					$K_1 \times 10^{-5}/M^{-1}$		n_1	
		Appr. \bar{n}	$\frac{LD}{A_T}$	λ/nm	$\frac{\Delta\epsilon}{\epsilon_r}$	θ/deg	(a)	(b)	(a)	(b)
[Pt(en)(dipy)] ²⁺	0.005	1	0.13	360			16±10	25±15	0.14±0.03	0.17±0.02
			-0.145	323	-0.25	90±5				
			-0.063	313						
			0.210	270						
	0.050	0.4	0.07	360			1.1±1.0		0.11±0.04	
			-0.10	323	-0.16	90±5				
			-0.05	313						
			-0.16	270						
			-0.16	257		≅90				
0.100		0.05	360			(0.29±0.5)	0.9±1.5	0.05±0.04	0.08±0.02	
		-0.045	323	-0.13	76±10					
		-0.02	313							
		-0.16	257		≅90					
[Cu(dipy) ₂] ²⁺	0.005	0.9	-0.014	324		5.1±2	1.3±0.2	0.20±0.03	0.20±0.05	
			0.025	312	+0.030					50±40
			-0.12	270						
	0.100	"0"		324			0.82±0.18		0.05±0.02	
			0.09	321		49±40				
			-0.29	257		≅90				
Dipy ^d	0.005		0.02	310	+0.08	(3±3)		(0.07±0.05)		
			-0.12	257						

^aFrom LD data. ^bFrom partition data. ^cCorrected for contribution from surrounding transitions. ^dDipy seems to bind as a neutral species.

TABLE II. Circular Dichroism Induced in the Ligand Absorption Bands.

Ligand	Wavelength of Extremum/nm	$\epsilon_1 - \epsilon_r/M^{-1} \text{ cm}^{-1}$	$10^3 \times \epsilon_L/M^{-1} \text{ cm}^{-1}$ (wavelength of maximum in parenthesis)
[Pt(en)(dipy)] ²⁺	319	0±0.1	11 (305)
	329	-4±2	14 (317)
		free Pt(en)dipy ²⁺ :	13 (305)
			18 (317)
[Cu(dipy) ₂] ²⁺	305	9±4	22 (310)
	316	14±3	30 (298)
		free Cu(dipy) ₂ ²⁺ :	27 (308)
		free Cu(dipy) ²⁺ :	17 (299)
			17 (310)
Dipy	(280)	(>0) 4±1	20 (280) 0.018 (305)

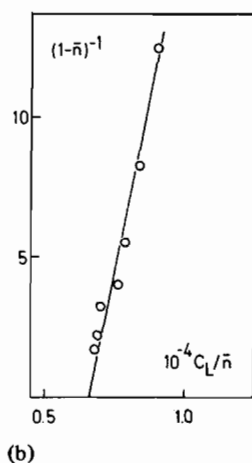
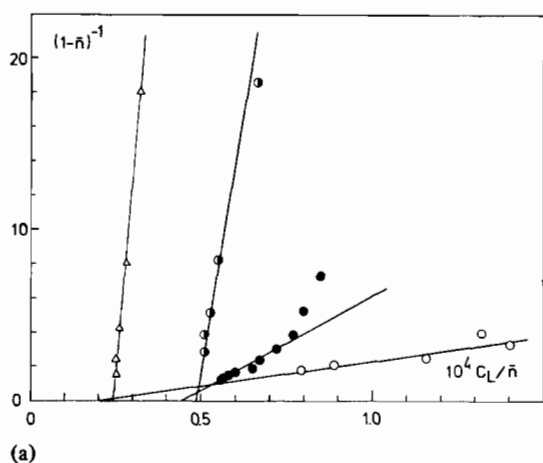

Fig. 5. $(1 - \bar{n})^{-1}$ versus C_L/\bar{n} plots based on the $\bar{n} = LD/LD_{\max}$ assumption. a. L = $[\text{Pt}(\text{en})(\text{dipy})]^{2+}$ (323 nm), $C_N = 1.50 \times 10^{-4} M$, $I = 0.005 M$ NaCl (Δ); $C_N = 3.90 \times 10^{-4} M$, $I = 0.005$ (\bullet); $C_N = 3.90 \times 10^{-4} M$, $I = 0.05$ (\circ); $C_N = 3.90 \times 10^{-4} M$, $I = 0.1$ (\circ). Stabilities (K_1) and ligand densities: $K_1 \times 10^{-4}/M^{-1} = 160 \pm 100$ ($n_1 = 0.14 \pm 0.02$) at $I = 0.005$, 11 ± 10 ($n_1 = 0.11 \pm 0.04$) for $I = 0.05$ and 2.9 ± 5 ($n_1 = 0.05 \pm 0.04$) for $I = 0.1$. b. L = $[\text{Cu}(\text{bipy})_{1-2}]^{2+}$ (312 nm), $C_N = 3.3 \times 10^{-4} M$, $I = 0.005 M$ NaCl. $K_1 = (5.1 \pm 2) \times 10^5 M^{-1}$, $n_1 = 0.20 \pm 0.03$.

reduced linear dichroisms LD/A . $\Delta\epsilon/\epsilon_r$ was estimated for pertinent transitions in DNA-L according to equation 4. The order parameter S was taken from the LD/A_r at 257 nm and values of θ were calculated (equation 5). For $[\text{Pt}(\text{en})(\text{dipy})]^{2+}$ other experiments [34] have shown that the two bands centred at 245 and 300–320 nm are due to transitions polarised within the PtN_4 -plane but perpendicular to each other. The transitions of the latter band are clearly parallel to the planes of the DNA bases (the deviation of θ from 90° for $I = 0.1 M$ is most probably due to an underestimated LD_{\max} , cf. Fig. 3). The direction corresponding to the 245 nm band also seems to have

this type of orientation as indicated by the negative LD contribution below 260 nm which can be separated from the intrinsic DNA absorption (see Fig. 2).

For the copper complex LD/A_r is less conclusive. Though the positive value excludes the possibility of intercalation, it may be consistent with a number of angular distributions which have their centre of gravity slightly below the "magic angle" 54.7° . On the other hand it is interesting to note that the pitch of the strands is likely to favour orientations around 40 – 50° of a planar non-intercalated ligands [25] (see however discussion). In view of the different coordination possibilities a study was made of LD/A_r at low and high C_L/C_N ratios. This did not however reveal any indication of a significant structural variation (Table I).

During the course of this study it was found that dipyrindyl itself formed a complex with DNA as shown by a positive LD band at 310 nm (Fig. 4). This coincides with the development of a new absorption band (denoted L in Fig. 6). The L band can in principle be a charge transfer band but the low intensity is more consistent with an $n \rightarrow \pi^*$ transition, whose intensity is stimulated by the environment. The polarisation is then perpendicular to the molecular plane so that the positive LD is consistent with binding by intercalation. It is seen from Fig. 6b that the L band intensity at increasing C_L reaches a saturation value. An attempt to estimate the stability from A and LD according to the concept of equation 3 is shown in Fig. 6c.

In order to see whether the complexation caused any changed hydrodynamic properties of DNA, LD/A_r at 257 nm was measured as a function of \bar{n} (Fig. 7) and as a function of the velocity gradient (Fig. 8). The Pt and Cu complexes show slightly different $LD-\bar{n}$ curves; for Pt there is an immediate decrease (possibly an effect of unwinding) and finally a trend upwards, while for Cu (as for dipy) LD decreases monotonically, and more rapidly at the end. The curves in Fig. 8 essentially reflect the behaviour of the orientation factor S . They have shapes characteristic of a gradually developing chain. As expected if the ligands are evenly distributed over the chains the intrinsic ligand LD and the intrinsic DNA LD give equivalent shapes. Both for the Pt and Cu complexes there is a slight difference from the pure DNA curve.

The results of the equilibrium analyses by the two-phase partition method are presented in Fig. 9. It was not possible to decide from these data or by standard methods (NMR, IR) whether $\text{Cu}(\text{dipy})_2^{2+}$ was coordinating with $x = 1$ or 2. An amount of dipyrindyl which was set free, and a low average ϵ_{308} (12000), obtained at very low C_L could indicate the presence of the mono-dipy complex. However within the experimental error this effect can be explained by the expected degree of dissociation of $[\text{Cu}(\text{dipy})_2]^{2+}$.

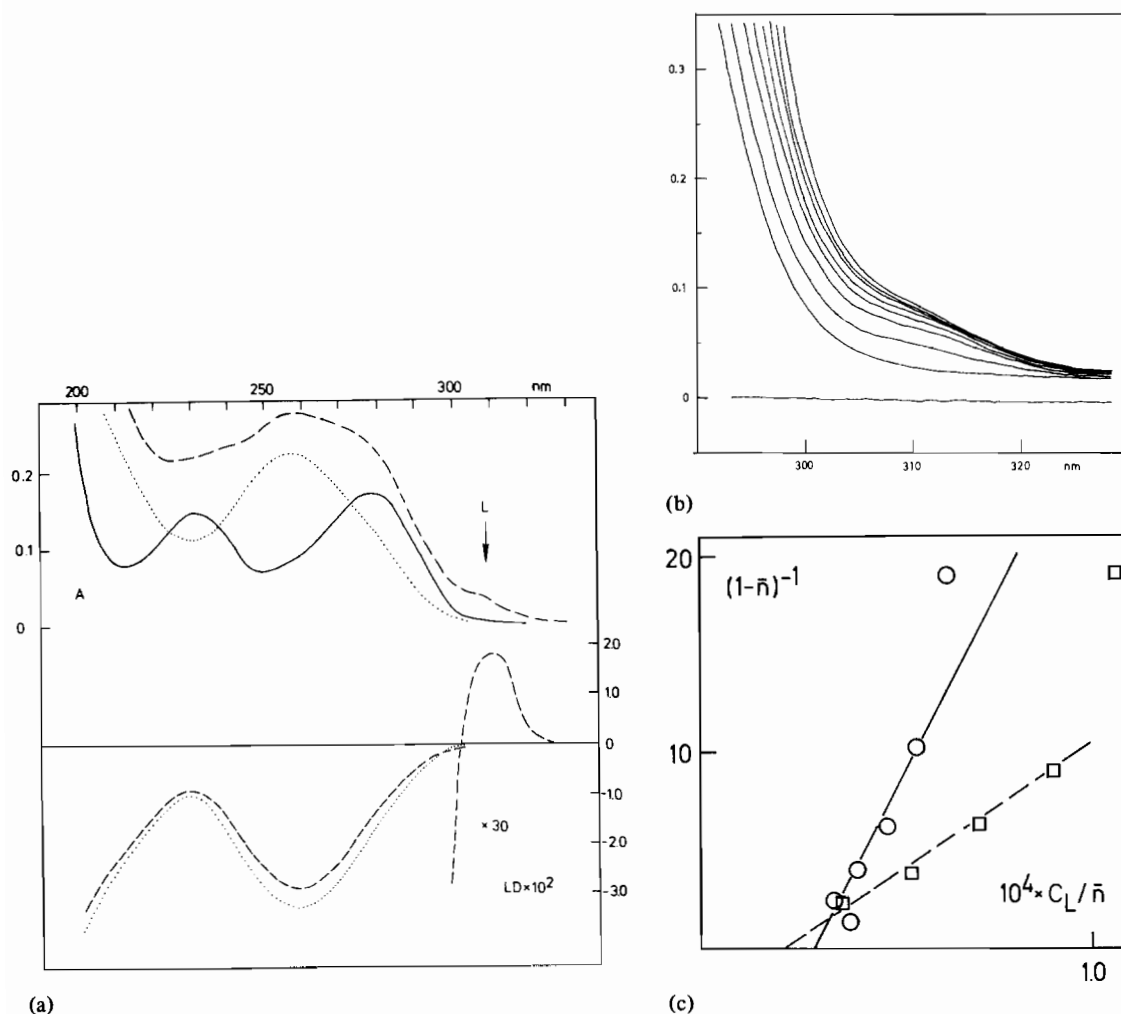

Fig. 6. (a) Absorbance (top) and linear dichroism (bottom) of DNA + dipyriddy ($C_N = 3.1 \times 10^{-4} M$, $C_L = 1.13 \times 10^{-4} M$, ---) of pure DNA ($C_N = 3.3 \times 10^{-4} M$, ...) and of pure dipyriddy ($C_L = 1.13 \times 10^{-4} M$, —). L = new band in the complex (0.10 cm path-length). (b) L-band: 2 ml DNA ($C_N = 3.3 \times 10^{-4} M$) + x ml $20 \times 10^{-4} M$ bipyridyl ($x = 0, 0.01, 0.02, 0.03, 0.04, 0.05, 0.06$ and 0.08 ml) 1 cm path-length. (c) $(1 - \bar{n})^{-1}$ versus C_L / \bar{n} plot based on the LD at 310 nm (◻) and the absorption of the L-band (○). $K_1 = (3.8-1.3) \times 10^5 M^{-1}$ and $n_1 = 0.089-0.064$.

As will be shown below (Fig. 10) the characteristic LD and CD bands around 300 nm derive practically exclusively from the complex with $\text{Cu}(\text{dipy})_2$. The circular dichroism data (Fig. 1, 3, Table III) show that the complex with $\text{Cu}(\text{dipy})_2^{2+}$ exhibits a strong CD in the ligand band compared to the Pt complex (the CD strength of the L band in the dipy complex is difficult to estimate due to the uncertain stability). For $\text{Cu}(\text{dipy})_2^{2+}$ the CD and LD magnitudes seem to be very small (less than 10% of those of the bis-dipy complex) which can be an effect of a weaker bonding. If $\text{Cu}(\text{H}_2\text{O})_6^{2+}$ is added to DNA (typically $C_L = 10^{-4} M$) a strong decrease in LD/A_τ at 257 nm indicates denaturation or compaction. Such an effect, though not so pronounced, was observed if $[\text{Cu}(\text{dipy})_2]^{2+}$ was added, or produced as in Fig. 10c.

Discussion

$[\text{Pt}(\text{en})(\text{dipy})]^{2+}$ is substitutionally inert in the time range employed and LD and stability conclusively demonstrate that this ion is bound to DNA in a manner consistent with the "intercalation model" suggested by Lerman [35] to explain the high affinity of planar aromatic dyes for DNA. The similarity between the molecular geometries of Pt(II) terpyridyls and the acridine dyes has recently been mentioned [28]. With a neighbour exclusion, *i.e.* with maximum one site in every second base pair slot, an $n_1 = 0.25$ is expected; this ligand density might be approached at extremely low ionic strength (Table I). The lower n_1 at higher ionic strength can be seen as an effect of inter-ligand repulsion. If we neglect the

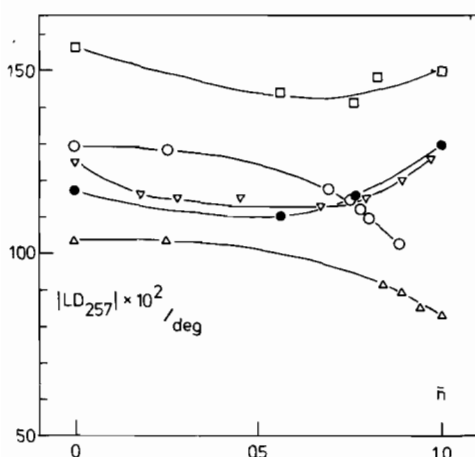
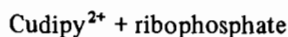
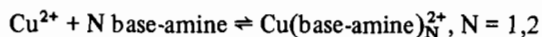
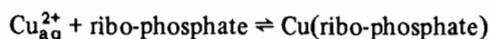
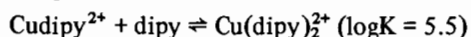
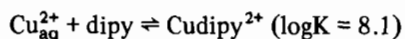

Fig. 7. Linear dichroism of the base absorption (257 nm) in DNA-L as a function of \bar{n} . L = [Pt(en)(dipy)]²⁺ ($C_N = 3.94 \times 10^{-4} M$), I = 0.005 (□), I = 0.05 (●), I = 0.1 (▽). L = [Cu(bipy)₂]²⁺, I = 0.005 (○). L = bipyridyl, I = 0.005 (△). LD corrected for dilution.

possibility of base specificity the series would be: $n_1 = 0.5$ (each slot), 0.25 (nearest neighbour exclusion), 0.17 (every third slot), 0.125 and so on corresponding to inter-ligand separations of 3.4, 10.2, 13.6, 17.0 Å...

While the PtN₄ system is planar and thus well suited for intercalation, [Cu(dipy)₂]²⁺ must be twisted due to interactions of the 3,3'-hydrogens between the two dipy ligands. A general tendency can also be noticed in chelate amine complexes to become severely distorted from planarity [36, 37]. From thermodynamic evidence an octahedral type of configuration has been concluded: *cis*[Cu(dipy)₂(H₂O)₂]²⁺ [38]. The positive LD (from bands polarised in the CuN₂-planes) [34] indicating that this complex is not intercalated, is therefore not surprising. Unfortunately, copper amines unlike the Pt compounds are kinetically labile and we have to consider a number of equilibria:



and so on. The two types of DNA interaction should carry with them some rather interesting consequences (as indicated from a large number of studies with simple hydrated metal ions) [5, 6]: Complex with phosphate means stabilisation of ordered structures (but cleavage of phosphodiester-polyribonucleotide bonds at elevated temperature), complex with bases

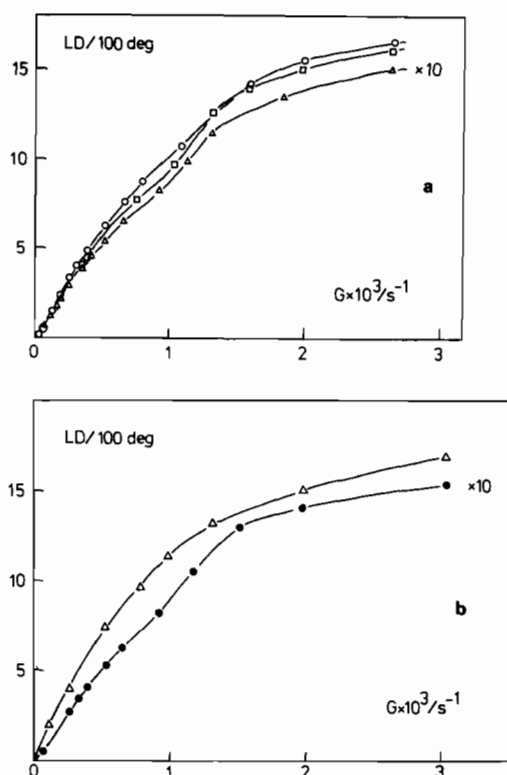

Fig. 8. LD versus gradient for a. DNA + [Pt(en)(dipy)]²⁺ ($C_N = 3.9 \times 10^{-4} M$, I = 0.05 M NaCl, $C_L = 0$, ○ at 257 nm; $C_L = 0.65 \times 10^{-4} M$, □ 257 nm, △ 323 nm). b. DNA + [Cu(dipy)₂]²⁺ ($C_N = 3.9 \times 10^{-4} M$, I = 0.005 M NaCl, $C_L = 0$, △ at 257 nm; $C_L = 1.07 \times 10^{-4} M$, ● 313 nm).

means destabilisation of ordered structures. $\text{Cu}(\text{H}_2\text{O})_6^{2+}$ is known to strongly decrease the melting point of DNA by binding to bases. The strongly decreased LD/A at 257 nm upon addition of small amounts of CuSO_4 is consistent with a (partial) strand separation. If a solution of equi-molar ($10^{-4} M$) quantities of Cu^{2+} and dipy is added to a DNA solution ($C_N = 2 \times 10^{-4} M$), LD and CD spectra arise which are apparently identical with those obtained with $\text{Cu}(\text{dipy})_2^{2+}$ but with *ca.* 90% lower magnitudes. A decrease of 10–30% is observed in LD at 257 nm.

These observations could be explained with a disproportionation of [Cu(dipy)]²⁺ into $\text{Cu}(\text{H}_2\text{O})_6^{2+}$ (responsible for the denaturation) and [Cu(dipy)₂]²⁺ (giving the observed LD and CD) due to the withdrawal of these species from the Cu-dipy equilibria. This can indicate that the mono-dipy copper complex forms a considerably weaker complex with DNA than the bis complex. In order to test this hypothesis LD and CD curves were run on solutions of DNA with varying amounts of $\text{Cu}(\text{dipy})_2^{2+}$ (Fig. 10). Neither type of spectrum showed any change in shape when passing from low to high C_L and did therefore not indicate more than one DNA complex. A plot of LD

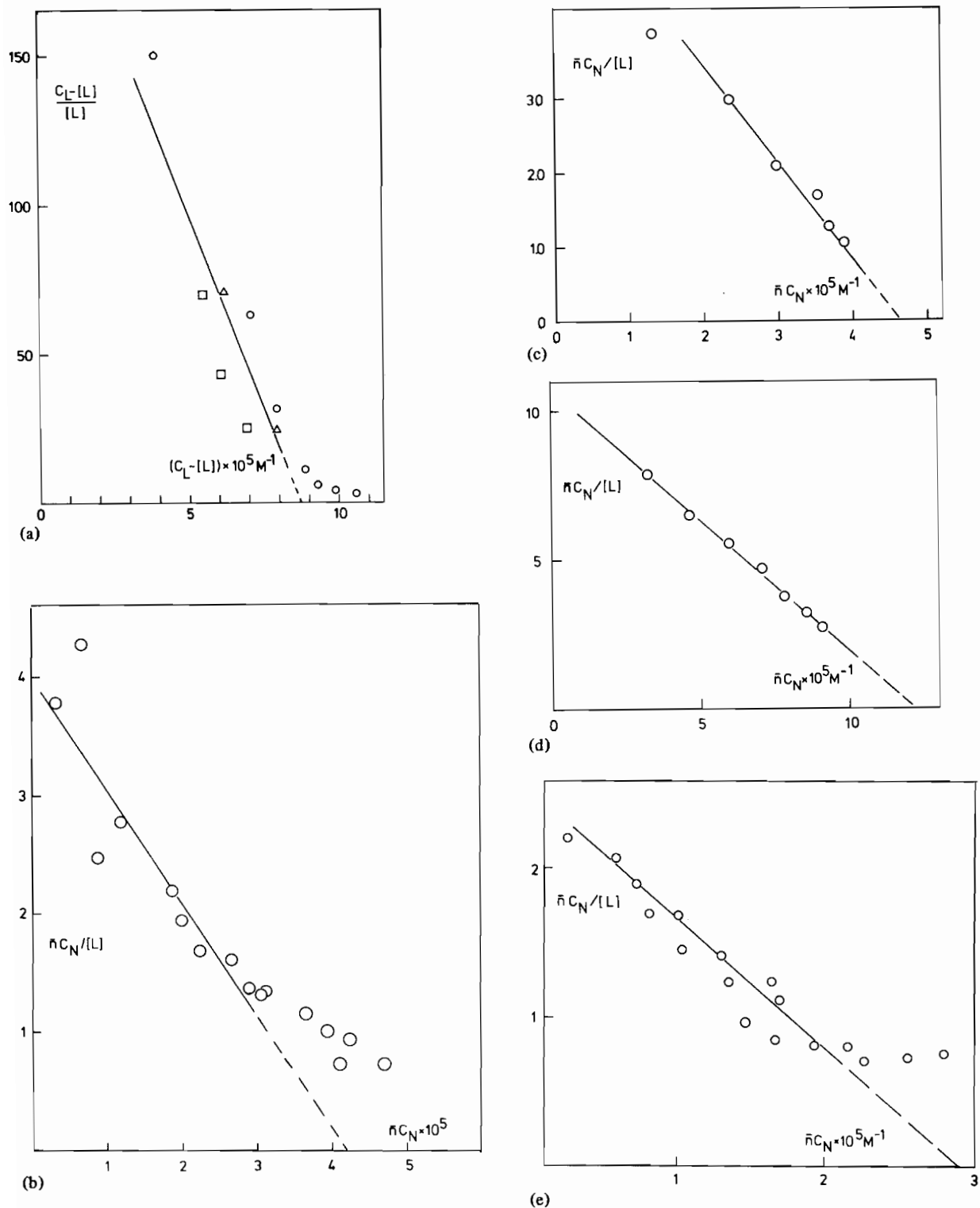

Fig. 9. Equilibrium analysis by means of dextrane/polyethyleneglycol two-phase partition technique. Stability obtained, $K_1/10^5 M^{-1}$: L = $[Pt(en)(dipy)]^{2+}$, a. 25 ± 15 ($n_1 = 0.17 \pm 0.02$) $C_N = 2.0 \times 10^{-4} M$, $I = 0.005 M$ NaCl. b. 0.95 ± 1.5 ($n_1 = 0.008 \pm 0.02$) $C_N = 5.2 \times 10^{-4} M$, $I = 0.10 M$ NaCl. L = $[Cu(bipy)_2]^{2+}$, c. 1.29 ± 0.2 ($n_1 = 0.20 \pm 0.05$), $C_N = 2.3 \times 10^{-4} M$, $I = 0.005 M$ NaCl. d. 0.86 ± 0.20 ($n_1 = 0.26 \pm 0.05$), $C_N = 4.7 \times 10^{-4} M$, $I = 0.005 M$ NaCl. e. 0.82 ± 0.18 ($n_1 = 0.05 \pm 0.02$) $C_N = 5.3 \times 10^{-4} M$, $I = 0.10 M$ NaCl.

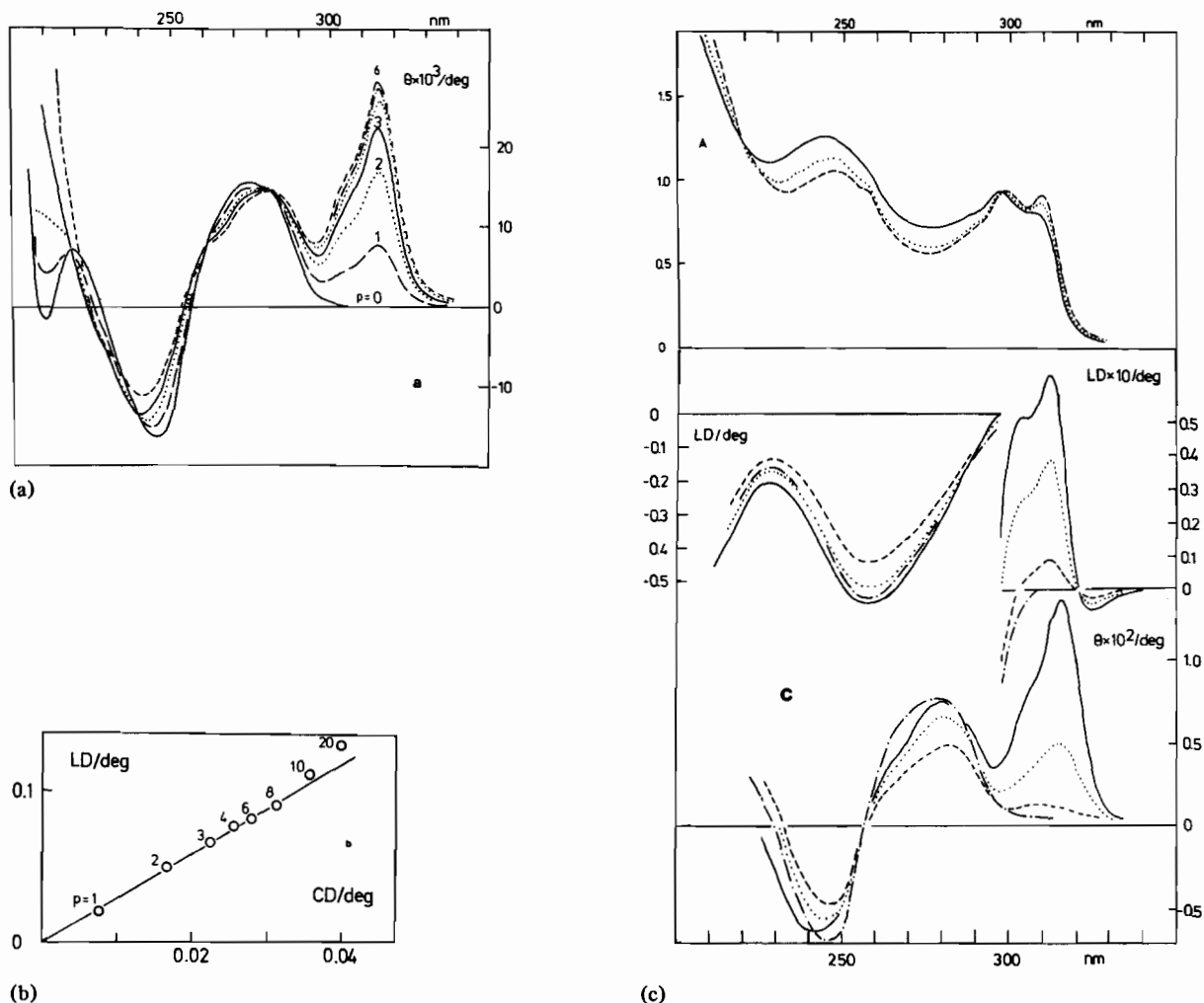

Fig. 10. DNA ($C_N = 2.63 \times 10^{-4} M$, $I = 0.005 M$ NaCl) + $Cu(dipy)_2^{2+}$ ($C_L = p \times 10^{-5} M$). a. CD spectra. b. LD (312 nm, $G = 2000 s^{-1}$) versus CD (316 nm) for the DNA- $Cu(dipy)_2^{2+}$ solutions. c. $[Cu(dipy)_2]^{2+}$ -DNA solution ($C_L = 7.4 \times 10^{-5} M$, $C_N = 2.63 \times 10^{-4} M$) before (—) and after the addition of $[Cu(H_2O)_6]^{2+}$: $C_{Cu^{2+}} = 3.7 \times 10^{-5} M$ (---) and $7.4 \times 10^{-5} M$ (- - -) (DNA: - · - ·). A and CD spectra refer to 0.50 cm path-length, LD to 0.10 cm path-length and $G = 2000 s^{-1}$.

versus CD was almost perfectly linear up to fairly large C_L (Fig. 10b). If $Cu(dipy)_2^{2+}$ and $Cu(dipy)_2^{2+}$ had been present as DNA complexes in comparable amounts a marked curvature should most probably have been observed as it is extremely unlikely that the two complexes should have identical LD to CD ratios. This result and the observation of an ϵ (310 nm) = $22 M^{-1} cm^{-1}$ for the complexed copper strongly suggests that practically all the amount of copper is present as $Cu(dipy)_2^{2+}$ (at very high C_L there is a deviation from linearity indicating the formation of a weaker complex, possibly peripherally associated $Cu(dipy)_2^{2+}$).

To get further support for this concept another experiment was made (see Fig. 10c): to a DNA- $Cu(dipy)_2^{2+}$ solution ($\bar{n} < 1$) $Cu(H_2O)_6^{2+}$ was added very slowly. If $Cu(dipy)_2^{2+}$ was the predominating

complexing agent the addition of free copper should increase the $Cu(dipy)_2^{2+}$ concentration and should hence give strongly reinforced LD and CD deflections. The strong decreases observed in both LD and CD (to practically zero when corrected for remaining $Cu(dipy)_2^{2+}$) therefore on the contrary indicate an exclusive predominance of $Cu(dipy)_2^{2+}$ as the active DNA ligand. The addition of Cu^{2+} leads to dissociation as a result of the larger stability of free $Cu(dipy)_2^{2+}$ compared to complexed $Cu(dipy)_2^{2+}$. It can be noted that the LD decrease at 257 nm is not very pronounced now showing that the base nitrogens are not serious competitors to dipy in complexing copper.

The affinity to amino or aza nitrogens makes it more probable that Cu coordinates to the bases than to phosphate oxygens. The hydrophobic environments within the grooves should further disfavour

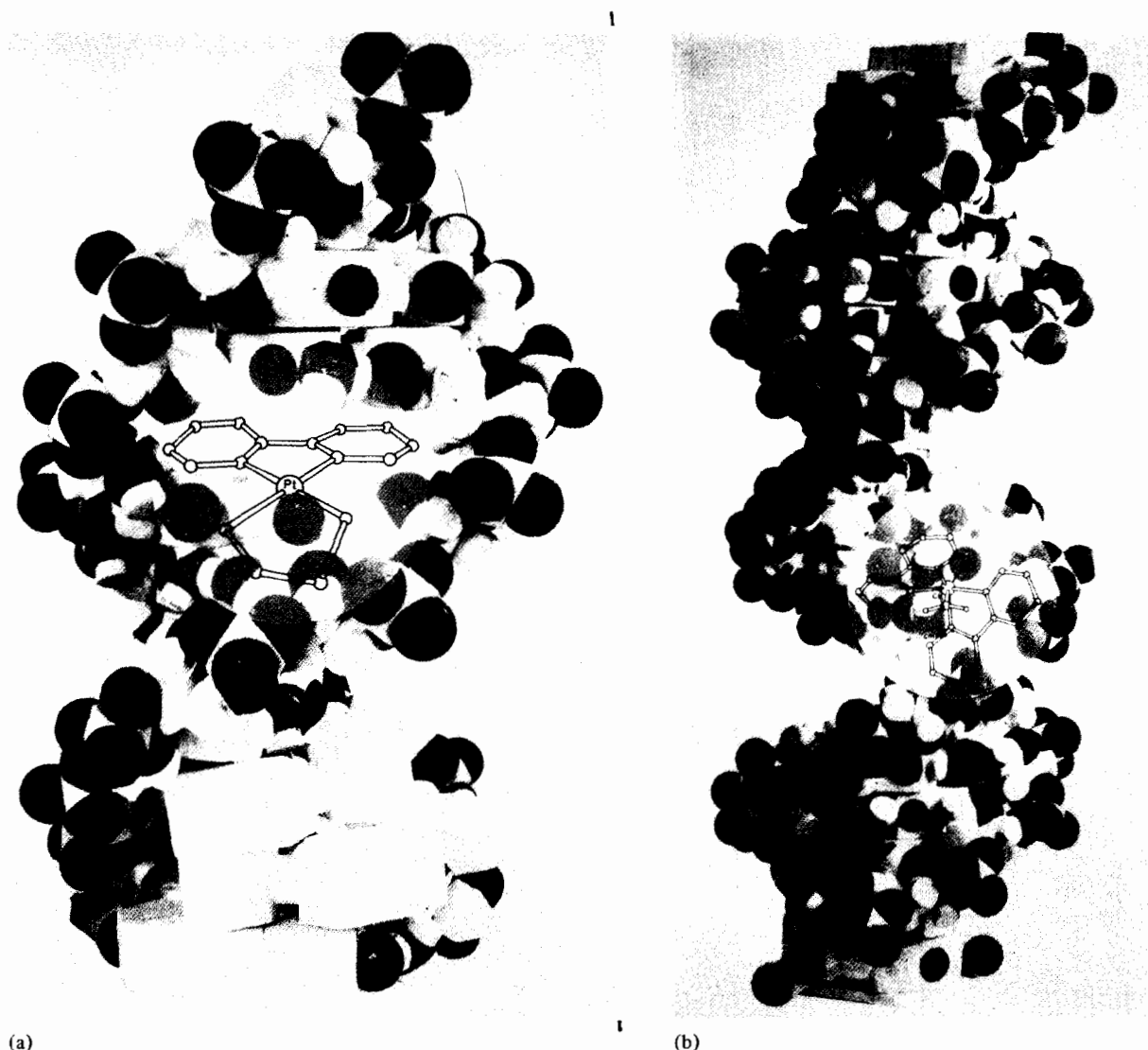

Fig. 11. Structures of the metal–DNA complexes: *a*. The planar $[\text{Pt}(\text{ethylenediamine})(\text{dipyridine})]^{2+}$ gaining binding energy by intercalation of the polarisable Pt–dipy moiety. *b*. The non-planar $[\text{Cu}(\text{dipyridyl})_2\text{H}_2\text{O}]^{2+}$ which is not intercalated but most likely bound to a base nitrogen, with the dipy ligands in contact with hydrophobic surfaces inside one of the grooves (taken to be in the large groove in the drawing. This position is consistent with a strong induced optical activity due to a screw in the (dipy)₂ system imposed by the helical strands.).

more hydrated species, such as $-\text{Cu}(\text{dipy})(\text{H}_2\text{O})_3^{2+}$, while $-\text{Cu}(\text{dipy})_2(\text{H}_2\text{O})^{2+}$ can be coordinated with the water in peripheral position (see Fig. 11). From models it is inferred that guanine could provide a chelatic *cis*-N-N-Cu(dipy)₂ coordination. Infrared [40] and ESR [41] studies have suggested that $\text{Cu}(\text{H}_2\text{O})_6^{2+}$ primarily binds to GC rich regions of DNA.

The circular dichroism of the intrinsic DNA absorption requires some comment. In the DNA– $[\text{Pt}(\text{en})(\text{dipy})]^{2+}$ complex there is no indication of any strong CD contribution from the Pt moiety so the change at shorter wavelengths can probably be attributed to a change in the DNA conformation. A trans-

ition of the “B → C” type, characterised by a shortening of the axial residue translations and by an increase of the rotations per residue (“winding angle”), should according to a frequently occurring concept be associated with a progressive decrease of the long-wavelength positive CD band and by a nearly invariant negative band at 245 nm, in apparent agreement with the observations in Fig. 1. It is interesting that no change is observed in the DNA– $[\text{Cu}(\text{dipy})_2]^{2+}$ complex, which can indicate that the DNA conformation is retained in conformity with a more peripheral binding.

It is clear that more investigation is needed to get a better characterisation of the reported DNA com-

plexes, particularly for the complicated copper system a traditional examination of the equilibria seems desirable. Nevertheless, the present evidence gives support for the existence of two different types of metal-DNA complexes. Their structures are schematically represented in Fig. 11.

Acknowledgement

This work was supported by the Swedish Natural Science Research Council (grant no. K 3216-009).

References

- 1 B. Rosenberg, L. van Camp and T. Krigas, *Nature*, **205**, 698 (1965).
- 2 B. Rosenberg, L. van Camp, J. E. Trosko and V. H. Mansour, *Nature*, **222**, 385 (1969).
- 3 B. Rosenberg and L. van Camp, *Cancer Res.*, **30**, 1799 (1970).
- 4 D. R. Williams, *Inorg. Chim. Acta Reviews*, **6**, 123 (1972).
- 5 G. L. Eichhorn in "Inorganic Biochemistry", Ed. G. L. Eichhorn, Wiley, London (1973).
- 6 G. L. Eichhorn and Y. A. Shin, *J. Am. Chem. Soc.*, **90**, 7323 (1968).
- 7 L. G. Marzilli in "Progress in Inorganic Chemistry", Vol. 23, Ed. S. J. Lippard, Wiley, London (1977).
- 8 D. J. Hodgson in "Progress in Inorganic Chemistry", Vol. 23, Ed. S. J. Lippard, Wiley, London (1977).
- 9 P. J. Bond, R. Langridge, K. W. Jennette and S. J. Lippard, *Proc. Nat. Acad. Sci. U.S.A.*, **72**, 4825 (1975).
- 10 J. Reuben and E. J. Gabbay, *Biochemistry*, **14**, 1230 (1975).
- 11 C. K. S. Pillai and U. S. Nandi, *Biochim. Biophys. Acta*, **474**, 11 (1977).
- 12 B. Nordén and F. Tjerneld, *FEBS Letters*, **67**, 368 (1976).
- 13 A. Wada in "Applied Spectroscopy Reviews", Vol. 6, Ed. E. G. Brame, M. Decker, New York (1973) p. 1.
- 14 H. J. Hofrichter and J. A. Schellman, in *The Jerusalem Symposia on Quantum Chemistry*, The Israel Academy of Sciences and Humanities, Jerusalem (1973).
- 15 J. Brahms, J. Pilet, T.-T. Phnong Lan and R. L. Hill, *Proc. Natl. Acad. Sci. U.S.A.*, **70**, 3352 (1973).
- 16 H. Fritzsche, W. Pohle and H. Lang, *Studia Biophysica*, **55**, 113 (1976).
- 17 B. Nordén and A. Davidsson, *Acta Chem. Scand.*, **26**, 842 (1972).
- 18 A. Davidsson and B. Nordén, *Chem. Scr.*, **9**, 49 (1976).
- 19 A. Davidsson and B. Nordén, *Spectrochim. Acta*, **32**, 717 (1976).
- 20 B. Nordén and F. Tjerneld, *Biophys. Chem.*, **4**, 191 (1976).
- 21 E. Fredericq and C. Houssier, "Electric Dichroism and Electric Birefringence", Clarendon Press, Oxford (1973).
- 22 K. Yamoaka and H. Hashimoto, *Chem. Letters*, 465 (1976).
- 23 L. S. Lerman, *Proc. Natl. Acad. Sci.*, **49**, 94 (1963).
- 24 D. Lu, "Flow Dichroism Studies on Complexes of DNA with Benzopyrene and Acridine Orange", *Thesis*, University of California (1976).
- 25 B. Nordén and F. Tjerneld, *Chem. Phys. Letters*, **50**, 508 (1977).
- 26 B. Nordén, F. Tjerneld and E. Palm, *Biophys. Chem.*, **8**, 1 (1978).
- 27 B. Nordén, A. Davidsson and L. B.-A. Johansson, *Nature*, **261**, 400 (1976).
- 28 K. W. Jennette, S. J. Lippard, G. A. Vassiliades and W. R. Bauer, *Proc. Nat. Acad. Sci. U.S.A.*, **71**, 3839 (1974).
- 29 H. P. Jensen, J. A. Schellman and T. Troxell, *Appl. Spectr.*, **32**, 192 (1978).
- 30 G. T. Morgan and F. H. Burstall, *J. Chem. Soc.*, 965 (1934).
- 31 B. R. James and R. J. P. Williams, *J. Chem. Soc.*, 2007 (1961).
- 32 P.-A. Albertsson, "Partition of Cell Particles and Macromolecules", Wiley (1971).
- 33 A. Davidsson and B. Nordén, *Chem. Scr.*, **00**, 0000 (1978).
- 34 B. Nordén and H. Wallin, to be published.
- 35 L. S. Lerman, *J. Mol. Biol.*, **3**, 18 (1961).
- 36 E. Larsen, S. Larsen, S. Røfen and K. J. Watson, *Acta Chem. Scand.*, **A30**, 125 (1976).
- 37 H. P. Jensen and E. Larsen, *Acta Chem. Scand.*, **25**, 1439 (1971).
- 38 J. Bjerrum and C. K. Jørgensen, *Rec. Trav. Chim.*, **75**, 658 (1956).
- 39 H. Sigel, *Inorg. Chim. Acta*, **6**, 195 (1972).
- 40 H. Fritzsche, *Eur. J. Biochem.*, **5**, 42 (1968).
- 41 C. Ropars and R. Viovy, *J. Chim. Phys.*, 408 (1965).